



HDT

For all FLH Harley Models



FEATURES



- Maintenance Free
- Large trunk
- Independent rear suspension
- 10" longer wheelbase
- Large automotive disc brakes
- Longer, Stronger Gates Poly Chain Belt
- Uses "off the shelf" auto parts
- Built-in trailer hitch



OPTIONS



- Electric Reverse
- Steering Kit
- Running Boards
- Black Wheel (2014 HDs)
- Chrome Wheels
- Performance Sway Bar
- Chrome rear bumper
- Accuride™ (Auto Leveling System)



BELT DRIVE CHASSIS



As the very first company to employ independent rear suspension on its trike conversions, Roadsmith continues to lead the way in design and innovation within the trike industry. A key feature of our trailing arm independent suspension is the absence of unnecessary moving parts, virtually eliminating any adjustments or maintenance.

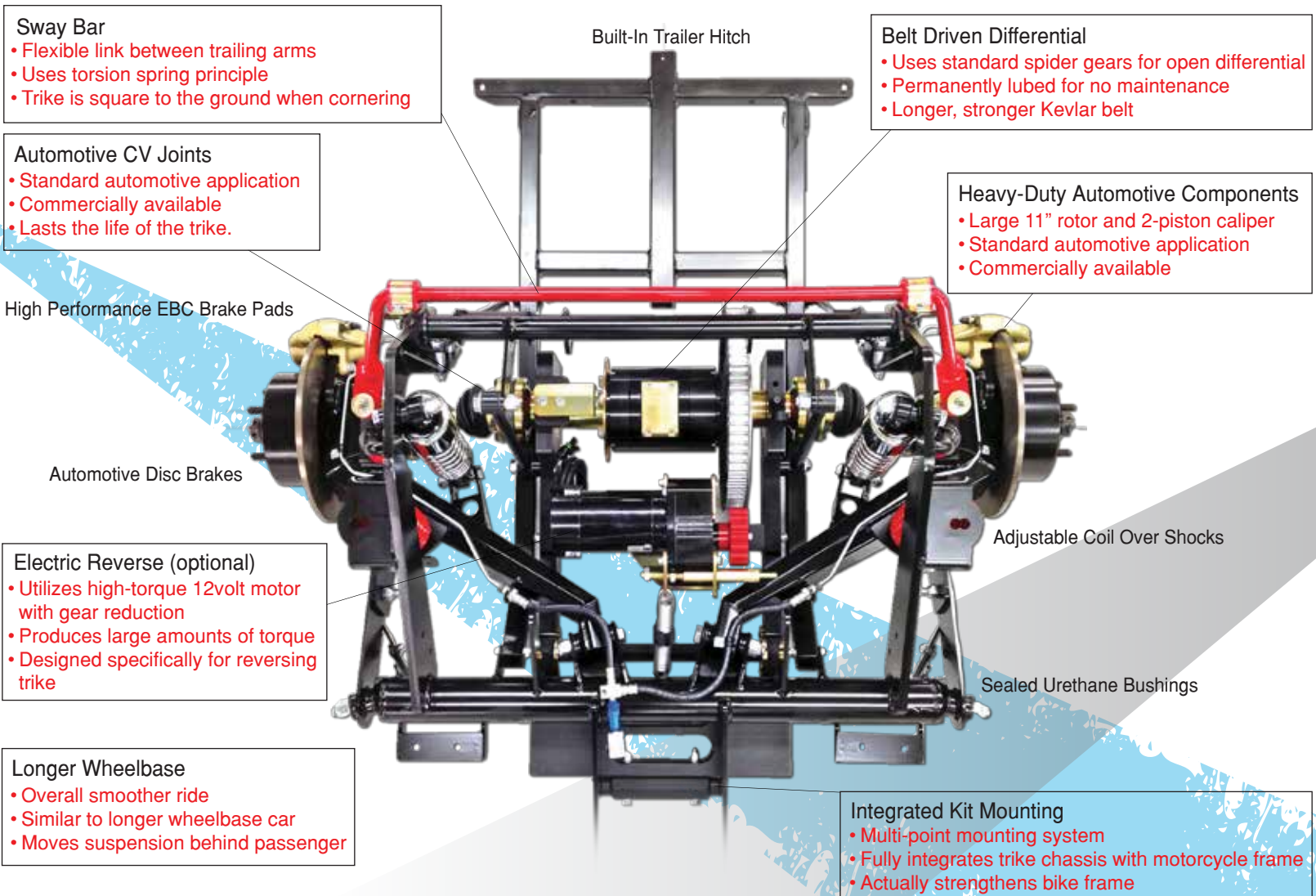

Sway Bar

- Flexible link between trailing arms
- Uses torsion spring principle
- Trike is square to the ground when cornering

Automotive CV Joints

- Standard automotive application
- Commercially available
- Lasts the life of the trike.

High Performance EBC Brake Pads

Automotive Disc Brakes

Electric Reverse (optional)

- Utilizes high-torque 12volt motor with gear reduction
- Produces large amounts of torque
- Designed specifically for reversing trike

Longer Wheelbase

- Overall smoother ride
- Similar to longer wheelbase car
- Moves suspension behind passenger

Virtually Maintenance Free

- Easiest trike kit to own
- No grease fittings
- Just ride and enjoy!

Built-In Trailer Hitch

Belt Driven Differential

- Uses standard spider gears for open differential
- Permanently lubed for no maintenance
- Longer, stronger Kevlar belt

Heavy-Duty Automotive Components

- Large 11" rotor and 2-piston caliper
- Standard automotive application
- Commercially available

Adjustable Coil Over Shocks

Sealed Urethane Bushings

Integrated Kit Mounting

- Multi-point mounting system
- Fully integrates trike chassis with motorcycle frame
- Actually strengthens bike frame

SPECIFICATIONS

Wheelbase.....	77"
Overall length.....	108"
Overall width.....	59"
Weight.....	1150 Lbs wet
Storage.....	27" wide x 14" high opening x 15" deep
Suspension.....	Lateral trailing arm Independent Rear Suspension
Suspension Adj.....	Manually adjustable coil-over shocks
Stabilizer bar.....	5/8" bar to control body roll
Tires, rear.....	215/55-16 radial
Rims, rear.....	16x7 alloy 5x4 1/2 35mm offset
Final drive ratio.....	Same as bike
Brakes, rear.....	Dual 35mm piston calipers
Body material.....	Polyester resin fiberglass
Drive system.....	160 tooth Gates PolyChain Carbon Fiber 1" wide

3744 Scheuneman Rd
White Bear Lake, MN 55110
800.331.0705
www.roadsmithtrikes.com
RIDE WITH THE EXPERT

**3 YEAR
1,000,000
MILE WARRANTY**